

IF IN DOUBT ASK

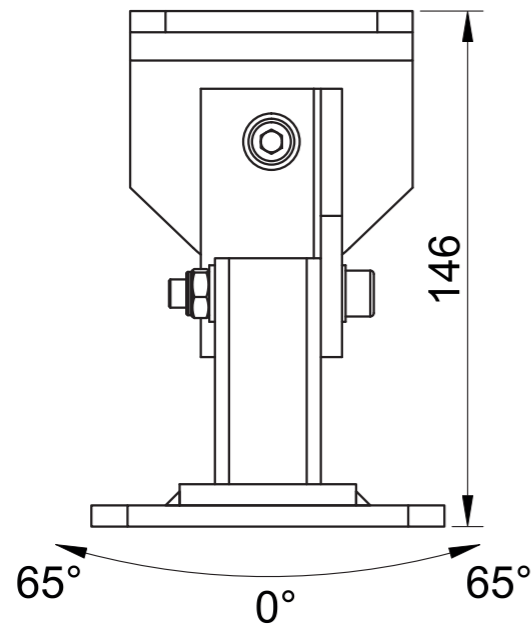
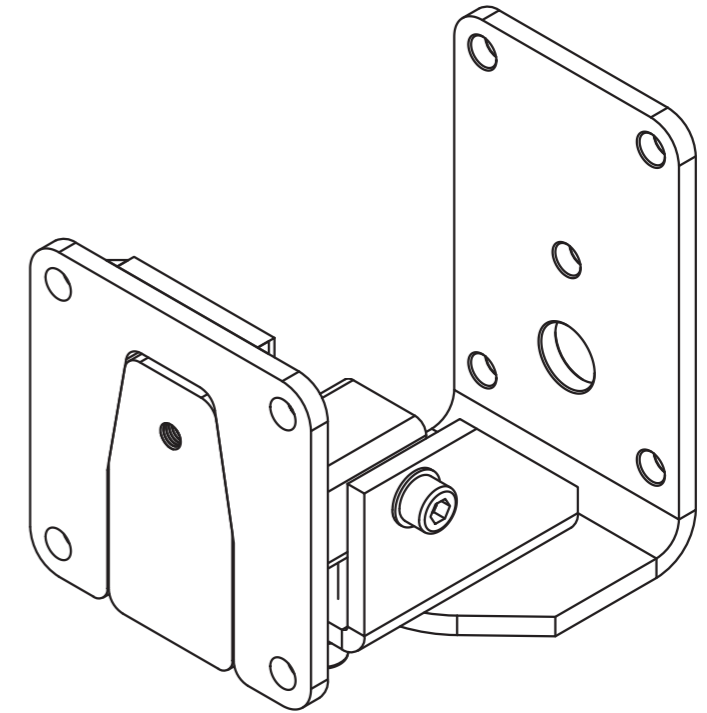
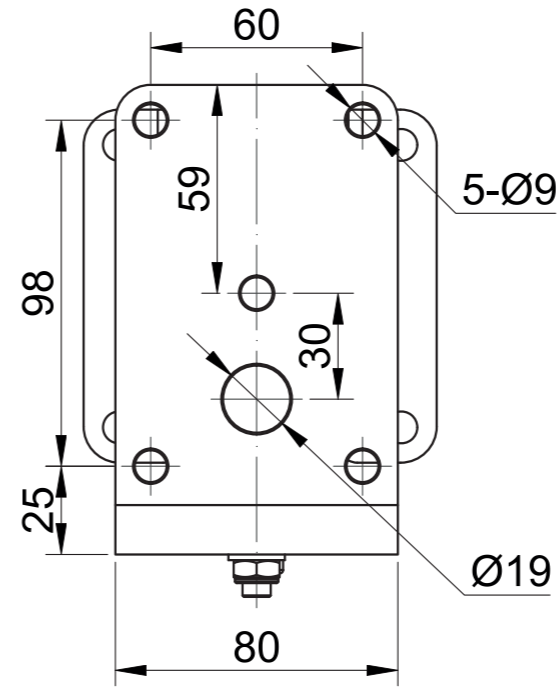
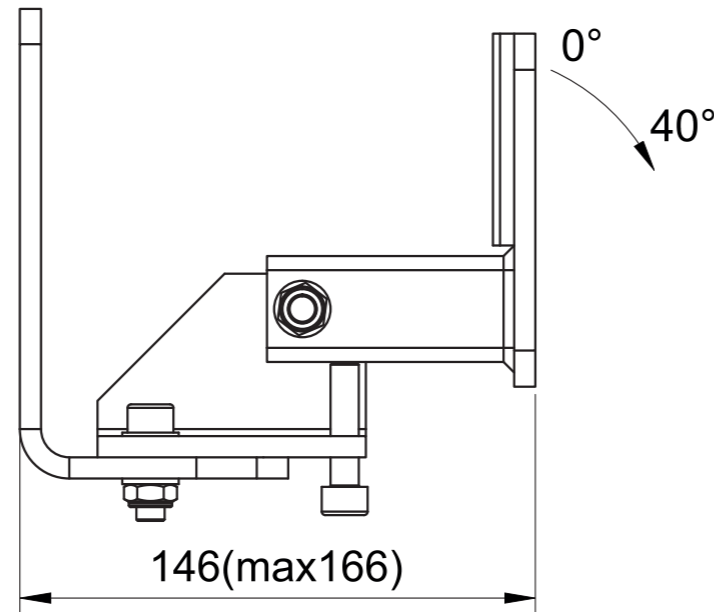
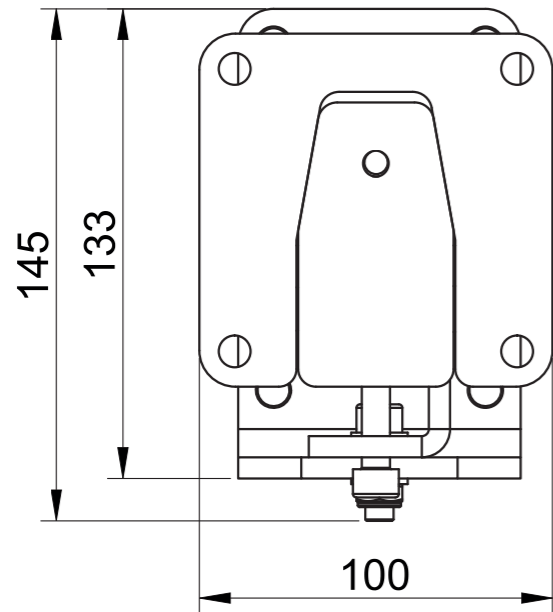
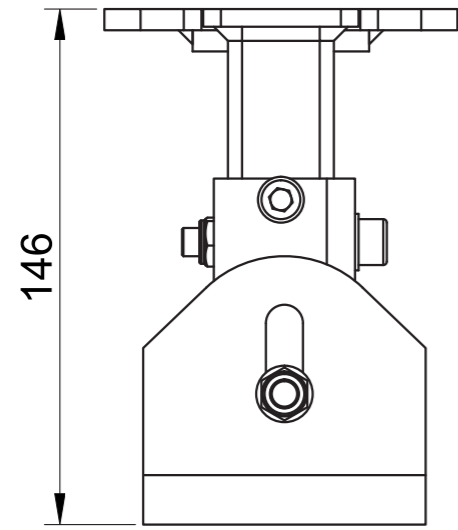

	NAME	DATE	DIMENSIONS IN MILLIMETRES				
DRAWN			FABRICATION <small>UNLESS OTHERWISE STATED</small>		MACHINING <small>UNLESS OTHERWISE STATED</small>		
			UP TO 300mm	+/-0.2mm	0, mm	+/- 0.5 mm	BREAK EDGE
CHECKED			300mm-500mm	+/-0.5mm	0,0 mm	+/- 0.2 mm	0.05 - 0.15mm
			500mm-1m	+/-1.0mm	0,00mm	+/- 0.1mm	FILLET RADDS
APPROVED			1m - 5m	+/-2.0mm	0,000mm	+/- 0.01mm	0.1 - 0.3mm
			ANGULAR	±1°	ANGULAR	±0.5°	

SURFACE TEXTURE VALUES IN MICROMETRES (µm) TO BS1134-PT2. ALL MACHINED SURFACES TO BE ✓ ALL SCREW THREADS TO BS3643 PT.2.

TITLE: EASY HANG		DRAWING No.	
PROJECT:		SAP No. IT1107	REV.
MATERIAL: AS ABOVE	GUAGE: (mm)	EST. WEIGHT: (Kg) 4.31	
FINISH: POWDER COAT MATT (HMG)	COLOUR: BLACK	TEXTURE: SMOOTH	
THIRD ANGLE PROJECTION TO BS 8888	SCALE: 1:1	SHT 1 OF 1 SHTS	SHEET: A3



REPRODUCTION OF ANY PART OF THIS DOCUMENT IS FORBIDDEN WITHOUT PRIOR PERMISSION FROM VOID ACOUSTICS RESEARCH LTD.
Registered in England & Wales No. 07533536
 DESIGN COPYRIGHT RESERVED.
 CONFIDENTIAL AND PROPRIETARY INFORMATION OF VOID ACOUSTICS RESEARCH LTD.